



Operating Instructions and Parts Manual Oscillating Edge Sander

Model: OES-80CS



JET
427 New Sanford Road
LaVergne, Tennessee 37086
Ph.: 800-274-6848
www.jettools.com

Part No. M-708447
Revision C 03/2014
Copyright © 2014 JET

Warranty and Service

JET warrants every product it sells against manufacturers' defects. If one of our tools needs service or repair, please contact Technical Service by calling 1-800-274-6846, 8AM to 5PM CST, Monday through Friday.

Warranty Period

The general warranty lasts for the time period specified in the literature included with your product or on the official JET branded website.

- JET products carry a limited warranty which varies in duration based upon the product. (See chart below)
- Accessories carry a limited warranty of one year from the date of receipt.
- Consumable items are defined as expendable parts or accessories expected to become inoperable within a reasonable amount of use and are covered by a 90 day limited warranty against manufacturer's defects.

Who is Covered

This warranty covers only the initial purchaser of the product from the date of delivery.

What is Covered

This warranty covers any defects in workmanship or materials subject to the limitations stated below. This warranty does not cover failures due directly or indirectly to misuse, abuse, negligence or accidents, normal wear-and-tear, improper repair, alterations or lack of maintenance.

Warranty Limitations

Woodworking products with a Five Year Warranty that are used for commercial or industrial purposes default to a Two Year Warranty. Please contact Technical Service at 1-800-274-6846 for further clarification.

How to Get Technical Support

Please contact Technical Service by calling 1-800-274-6846. **Please note that you will be asked to provide proof of initial purchase when calling.** If a product requires further inspection, the Technical Service representative will explain and assist with any additional action needed. JET has Authorized Service Centers located throughout the United States. For the name of an Authorized Service Center in your area call 1-800-274-6846 or use the Service Center Locator on the JET website.

More Information

JET is constantly adding new products. For complete, up-to-date product information, check with your local distributor or visit the JET website.

How State Law Applies

This warranty gives you specific legal rights, subject to applicable state law.

Limitations on This Warranty

JET LIMITS ALL IMPLIED WARRANTIES TO THE PERIOD OF THE LIMITED WARRANTY FOR EACH PRODUCT. EXCEPT AS STATED HEREIN, ANY IMPLIED WARRANTIES OF MERCHANTABILITY AND FITNESS FOR A PARTICULAR PURPOSE ARE EXCLUDED. SOME STATES DO NOT ALLOW LIMITATIONS ON HOW LONG AN IMPLIED WARRANTY LASTS, SO THE ABOVE LIMITATION MAY NOT APPLY TO YOU.

JET SHALL IN NO EVENT BE LIABLE FOR DEATH, INJURIES TO PERSONS OR PROPERTY, OR FOR INCIDENTAL, CONTINGENT, SPECIAL, OR CONSEQUENTIAL DAMAGES ARISING FROM THE USE OF OUR PRODUCTS. SOME STATES DO NOT ALLOW THE EXCLUSION OR LIMITATION OF INCIDENTAL OR CONSEQUENTIAL DAMAGES, SO THE ABOVE LIMITATION OR EXCLUSION MAY NOT APPLY TO YOU.

JET sells through distributors only. The specifications listed in JET printed materials and on official JET website are given as general information and are not binding. JET reserves the right to effect at any time, without prior notice, those alterations to parts, fittings, and accessory equipment which they may deem necessary for any reason whatsoever. JET® branded products are not sold in Canada by JPW Industries, Inc.

Product Listing with Warranty Period

90 Days – Parts; Consumable items; Light-Duty Air Tools
1 Year – Motors; Machine Accessories; Heavy-Duty Air Tools; Pro-Duty Air Tools
2 Year – Metalworking Machinery; Electric Hoists, Electric Hoist Accessories; Woodworking Machinery used for industrial or commercial purposes
5 Year – Woodworking Machinery
Limited Lifetime – JET Parallel clamps; VOLT Series Electric Hoists; Manual Hoists; Manual Hoist Accessories; Shop Tools; Warehouse & Dock products; Hand Tools

NOTE: JET is a division of JPW Industries, Inc. References in this document to JET also apply to JPW Industries, Inc., or any of its successors in interest to the JET brand.

Table of Contents

Warranty and Service	2
Table of Contents	3
Warnings	4
Introduction	6
Specifications	6
Unpacking	7
Shipping Contents.....	7
Tools Needed for Assembly	7
Assembly	8
Stand Assembly	8
Installing Table and Motor Unit to Stand	8
Sanding Belt Installation.....	9
Drum Guard & Dust Port	10
Extension Table	10
Electrical	11
Grounding Instructions	11
115 Volt Operation	11
230 Volt Operation	11
Adjustments	12
Sanding Platen Angle Adjustment	12
Platen Lock Tension Adjustment	12
Changing the Sanding Belt.....	13
Belt Tracking Adjustment	13
Motor Mount Tracking Adjustment	14
Table Adjustment	14
Basic Operations	15
Horizontal Sanding.....	15
Vertical Sanding.....	15
Contour Sanding.....	16
Troubleshooting Operating Problems.....	17
Parts	17
Ordering Replacement Parts	17
Table and Motor – Assembly.....	18
Table and Motor – Parts.....	19
Idle Drum – Assembly	21
Idle Drum – Parts	22
Stand Assembly	23
Wiring Diagram.....	24

The specifications in this manual are given as general information and are not binding. JET reserves the right to effect, at any time and without prior notice, changes or alterations to parts, fittings, and accessory equipment deemed necessary for any reason whatsoever.

Warnings

1. Read and understand the entire owner's manual before attempting assembly or operation.
2. Read and understand the warnings posted on the machine and in this manual. Failure to comply with all of these warnings may cause serious injury.
3. Replace the warning labels if they become obscured or removed.
4. This Oscillating Edge Sander is designed and intended for use by properly trained and experienced personnel only. If you are not familiar with the proper and safe operation of an edge sander, do not use until proper training and knowledge have been obtained.
5. Do not use this machine for other than its intended use. If used for other purposes, JET disclaims any real or implied warranty and holds itself harmless from any injury that may result from that use.
6. Always wear approved safety glasses/face shields while using this Oscillating Edge Sander. Everyday eyeglasses only have impact resistant lenses; they are not safety glasses.
7. Before operating this edge sander, remove tie, rings, watches and other jewelry, and roll sleeves up past the elbows. Remove all loose clothing and confine long hair. Non-slip footwear or anti-skid floor strips are recommended. Do **not** wear gloves.
8. Wear ear protectors (plugs or muffs) during extended periods of operation.
9. Some dust created by power sanding, sawing, grinding, drilling and other construction activities contain chemicals known to cause cancer, birth defects or other reproductive harm. Some examples of these chemicals are:
 - Lead from lead based paint.
 - Crystalline silica from bricks, cement and other masonry products.
 - Arsenic and chromium from chemically treated lumber.Your risk of exposure varies, depending on how often you do this type of work. To reduce your exposure to these chemicals, work in a well-ventilated area and work with approved safety equipment, such as face or dust masks that are specifically designed to filter out microscopic particles.
10. Do not operate this machine while tired or under the influence of drugs, alcohol or any medication.
11. Make certain the switch is in the **OFF** position before connecting the machine to the power source.
12. Make certain the machine is properly grounded.
13. Make all machine adjustments or maintenance with the machine unplugged from the power source.
14. Form a habit of checking to see that all extra equipment such as adjusting keys, wrenches, scrap, stock, and cleaning rags are removed away from the machine before turning on.
15. Keep safety guards in place at all times when the machine is in use. If removed for maintenance purposes, use extreme caution and replace the guards immediately when maintenance is complete.
16. Make sure the edge sander is firmly secured to the floor before use.
17. Check damaged parts. Before further use of the machine, a guard or other part that is damaged should be carefully checked to determine that it will operate properly and perform its intended function. Check for alignment of moving parts, binding of moving parts, breakage of parts, mounting and any other conditions that may affect its operation. A guard or other part that is damaged should be properly repaired or replaced.
18. Provide for adequate space surrounding work area and non-glare, overhead lighting.
19. Keep the floor around the machine clean and free of scrap material, oil and grease.

Warnings

20. Keep visitors a safe distance from the work area. **Keep children away.**
21. Make your workshop child proof with padlocks, master switches or by removing starter keys.
22. Give your work undivided attention. Looking around, carrying on a conversation and “horse-play” are careless acts that can result in serious injury.
23. Maintain a balanced stance at all times so that you do not fall or lean against the sanding belt or other moving parts. Do not overreach or use excessive force to perform any machine operation.
24. Use the right tool at the correct speed and feed rate. Do not force a tool or attachment to do a job for which it was not designed. The right tool will do the job better and safer.
25. Use recommended accessories; improper accessories may be hazardous.
26. Maintain machinery with care. Follow instructions for lubricating and changing accessories.
27. Turn off the machine before cleaning. Use a brush or compressed air to remove dust or debris — do not use your hands.
28. Do not stand on the machine. Serious injury could occur if the machine tips over.
29. Never leave the machine running unattended. Turn the power off and do not leave the machine until it comes to a complete stop.
30. At all times hold the stock firmly.
31. Do not use this sander for other than it intended use. If used for other purposes, JET disclaims any real or implied warranty and holds itself harmless for any injury or damage which may result from that use.

Familiarize yourself with the following safety notices used in this manual:

CAUTION This means that if precautions are not heeded, it may result in minor injury and/or possible machine damage.

WARNING This means that if precautions are not heeded, it may result in serious injury or possibly even death.

Introduction

This manual is provided by JET covering the safe operation and maintenance procedures for a JET Model OES-80CS Sander. This manual contains instructions on installation, safety precautions, general operating procedures, maintenance instructions and parts breakdown. This machine has been designed and constructed to provide years of trouble free operation if used in accordance with instructions set forth in this manual. If there are any questions or comments, please contact either your local supplier or JET. JET can also be reached at our web site: www.jettools.com.

Specifications

Model	OES-80CS
Stock Number.....	708447
Fence (HxL)(in.)	4 x 24
Abrasive Belt Size (WxL)(in.)	6 x 89
Dust Chute Diameter (in.)	4
Extension Table Size (in.).....	9-7/8 x 11-7/8
Table Size (LxW)(in.).....	32 x 7
Table Tilt (deg.)	90
Motor.....	TEFC 1-1/2 HP, 1 PH, 115/230V (prewired 115V), 18/9 A, 60Hz
Belt Speed (SPFM).....	3,900
Oscillation Stroke (in.).....	1/2
Oscillations per Minute	108
Overall Dimensions (LxWxH)(in.).....	51 x 26.5 x 44
Net Weight, approximate (lbs.).....	258
Shipping Weight, approximate (lbs.).....	275

The above specifications were current at the time this manual was published, but because of our policy of continuous improvement, JET reserves the right to change specifications at any time and without prior notice, without incurring obligations.

Unpacking

Upon delivery, open shipping containers and check that all parts are in good condition. Any damage should be reported to your distributor and shipping agent immediately. Before proceeding further, read your manual and familiarize yourself thoroughly with assembly, maintenance and safety procedures.

Compare the contents of your container with the following parts list to make sure all parts are intact. Missing parts, if any, should be reported to your distributor. Read the instruction manual thoroughly for assembly, maintenance and safety instructions.

Tools Needed for Assembly

- 2 12mm Wrench or sockets
- 1 10mm Wrench or sockets
- 1 Flat Head Screw Driver
- 1 Cross Point Screw Driver

Shipping Contents

- 1 Front Panel with Door (Stand)
- 1 Rear Panel (Stand)
- 2 Side Panel (Stand)
- 1 Shelf
- 2 M5x10 Screw
- 2 M5 Flat Washer
- 2 M5 Lock Washer
- 1 Extension Table Assembly
- 1 Drum Guard & Dust Port
- 1 Owner's Manual
- 1 Warranty Card
- 1 Table and Motor Unit
- 1 Back Stop Bracket
- 1 Belt Tension Handle
- 1 Belt Tracking Tool
- 1 Miter Gauge Assembly
- 1 Sanding Belt

Cabinet Hardware

- 1 Lock Knob (20mm Length)
- 2 Lock Knob (12mm Length)
- 1 Lock Knob (35mm Length)
- 4 Cabinet Pads
- 4 5/16" x 5/8" Screws
- 22 5/16" Flat Washers
- 12 5/16" Hex Nuts
- 8 5/16" x 5/8" Hex Cap Bolts
- 2 5/16" x 1-1/4" Hex Cap Bolts
- 4 Larger O/D 5/16" Flat Washers
- 10 5/16" Lock Washers

Extension Table Hardware

- 5 1/4" x 5/8" Hex Cap Bolts
- 5 1/4" Flat Washers
- 5 1/4" Lock Washers
- 1 Bracket
- 2 10-24x3/4 Socket Head Cap Screws

Dust Chute Hardware

- 3 Pan Head Screws

Assembly

Stand Assembly

Referring to Figure 1:

1. Remove all contents from the shipping container.
2. Clean all rust protected surfaces with a mild solvent. Do not use paint or lacquer thinner, gasoline, or mineral spirits; these will damage painted surfaces.
3. Attach the four *rubber pads* (A) to the bottoms of the *side panels* (C) with four each 5/16" x 5/8" *screws*, 5/16" *flat washers* and 5/16" *hex nuts* (B). The hardware can be found in the bag with the rubber pads.
4. Attach the *side panels* (C) to the *front panel* (D) with four 5/16" x 5/8" *hex cap screws*, eight 5/16" *flat washers*, four 5/16" *lock washers*, and four 5/16" *hex nuts* (E). Hand tighten the hardware at this point.

Note: Assemble the stand upside down to make sure that the tops of the panels are flush.

5. Mount the *shelf* (F) to the inside of the stand with two M5x10 *pan head screws*, two M5 *flat washers* and two M5 *lock washers* (G).
6. Finish the stand assembly by attaching the *rear panel* (H) to *side panels* (C) with four 5/16" x 5/8" *hex cap screws*, eight 5/16" *flat washers*, four 5/16" *lock washers*, and four 5/16" *hex nuts* (J).
7. Make sure stand is sitting evenly on a level surface before tightening hardware.

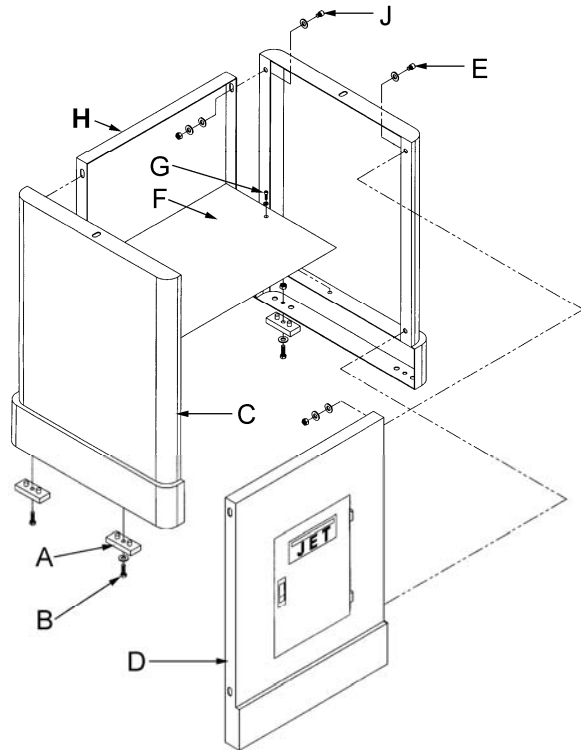

Figure 1

Installing Table and Motor Unit to Stand

⚠WARNING The Table and Motor Unit is heavy! Use great care and adequate resources when lifting the unit up onto the stand! Failure to comply may cause serious injury and/or damage to the sander and/or property!

Referring to Figure 2:

1. With the aid of another person, carefully lift the *table and motor unit* (A) out of the shipping box, and up onto the *stand* (B).
2. Line up threaded holes in the *base* (C) with the holes in the *stand* (D).
3. Open the *cabinet door* (E) and through the opening attach main unit to stand with two 5/16" x 1-1/4" *hex cap screws* (F), two 5/16" *lock washers* (G) and two 5/16" *flat washers* (H). Tighten with a 12mm wrench.

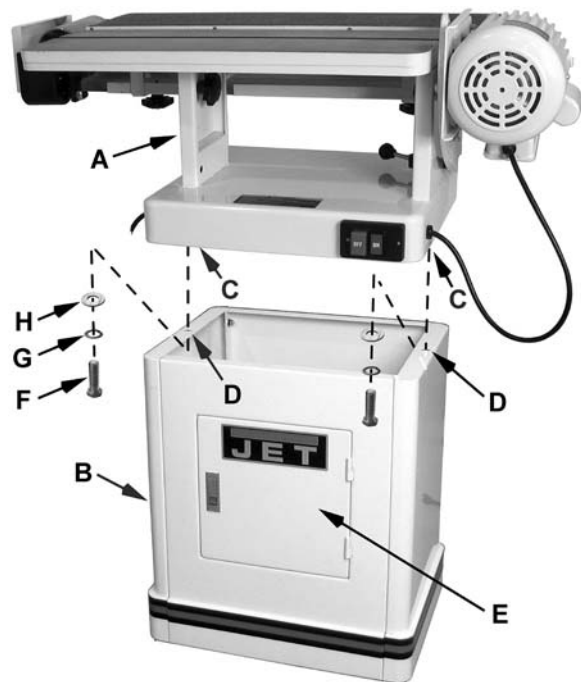

Figure 2

Referring to Figure 3:

4. The *sanding platen* (A) is presently in the horizontal position. Pull *lock handle* (B) forward to unlock the platen assembly.
5. Tilt sanding platen to the *vertical position* (C), which will look like D in Fig. 4; then push the *lock handle* (B) to lock the platen assembly in place.

Note: Do not *turn* the lock handle. *Turning* or *rotating* the lock handle will change the tension of the locking assembly. This may cause the locking assembly not to work, making it necessary for adjustment before using the machine.

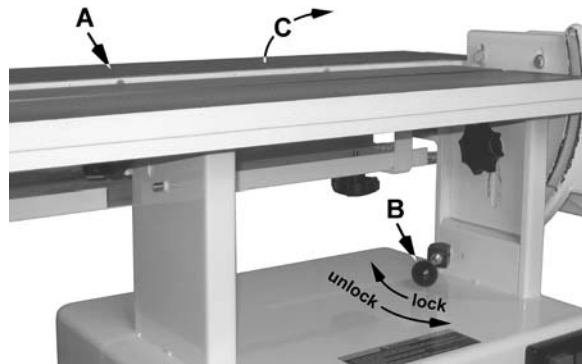

Figure 3



Figure 4

Sanding Belt Installation

Referring to Figure 5:

1. From the rear of the sander, remove the *belt guard* (A) by unscrewing two *lock knobs* (B). Take out the *sanding belt* and *removable fence* from behind the belt guard.
2. Place the *handle* (C) on *belt tensioning lever* (D). Remove the tension from the mechanism by moving the *handle* (C) to the *Loose* position.

3. Place belt on both rollers so that the edge of the belt is even with the edge of the rollers.

Note: Make sure that direction arrow on belt matches the direction indicator on the top of the platten.

4. Tighten the belt by moving the *tension arm handle* (C) to the *Tight* position. Rotate the belt by hand in the direction indicated by the arrow on top of the platten. If the belt tracking needs adjustment, see *Belt Tracking Adjustment* on page 13.

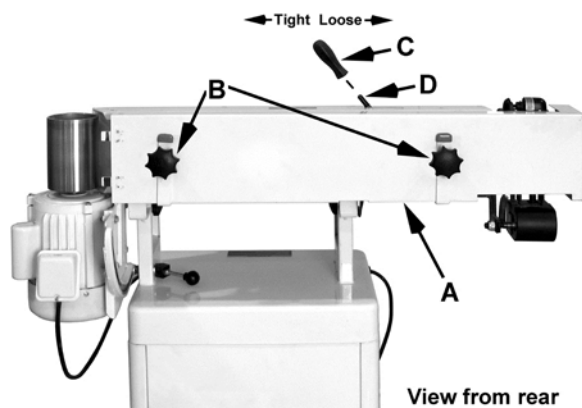

Figure 5

Drum Guard & Dust Port

Referring to Figure 6:

Mounting the Drum Guard & Dust Port (referred to below as *drum guard*)

1. Insert four M4x20 *flat head screws* (A) through the two *hinges* (B) of the *drum guard* (C). Then place two rectangular *spacers* (D) on the threaded ends of the screws.

Note: Orient the spacers so the slightly *rounded side* sits against the hinge and the edge *farther* from the screws lines up with the edge of the hinge.

2. Secure the *drum guard* (A) to the *belt guard* on the rear side of the sander by threading the screws through the *mounting holes* (E) in the belt guard. Tighten the screws.

Mounting the Connection Plate

3. Place the *drum guard* (C) in the closed position – this will cover the *drive drum* (J).

Note: You may have to slightly lift the cover when closing in order to clear the motor case. This is normal.

4. Place *washers* (G) on two small *lock knobs* (H) and then insert the threaded end of one lock knob through the slot of the *connection plate* (F) and the other lock knob through the hole of the *connection plate*.
5. Secure the slotted side of the extension plate to the *drum guard* (C) and the side with the hole to the *belt guard* (E).

When repositioning the drum guard, slightly loosen both lock knobs, open or close the cover, then secure the lock knobs.

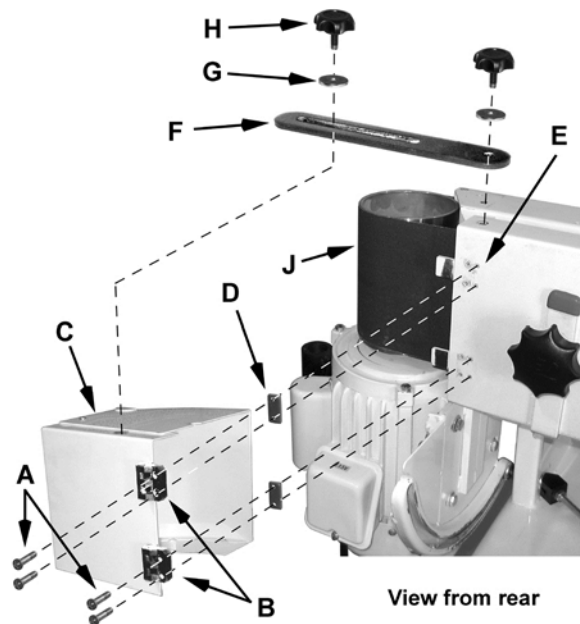

Figure 6

Extension Table

Referring to Figure 7:

1. Attach the *bracket* (E) for the extension table to the side of the *motor housing* (D) and secure with two *socket head cap screws* (F).
2. Slide the shaft of the *extension table* (C) into the *bracket* (E), positioning the table so the *opening* (B) wraps around the *drive drum* (A).
3. Insert *lock knob* (G) into the threaded hole on the side of the *bracket* (E) visible from the rear of the sander.

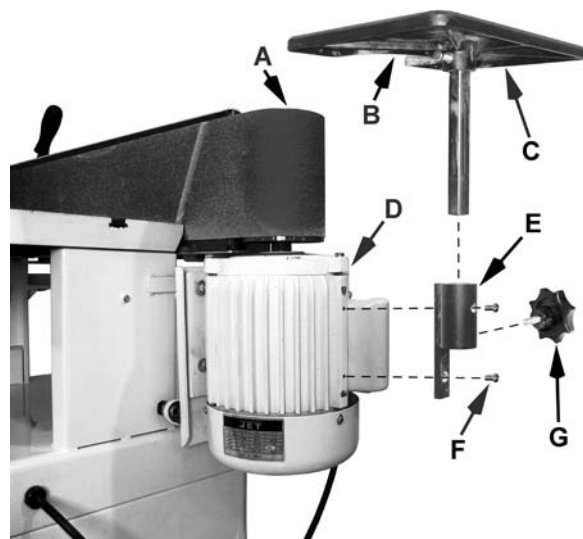

Figure 7

Electrical

Grounding Instructions

CAUTION This sander must be grounded while in use to protect the operator from electric shock.

In the event of a malfunction or breakdown, grounding provides a path of least resistance for electric current to reduce the risk of electric shock. This tool is equipped with an electric cord having an equipment-grounding conductor and a grounding plug. The plug must be plugged into a matching outlet that is properly installed and grounded in accordance with all local codes and ordinances.

Do not modify the plug provided. If it will not fit the outlet, have the proper outlet installed by a qualified electrician. Improper connection of the equipment-grounding conductor can result in a risk of electric shock. The conductor, with insulation having an outer surface that is green with or without yellow stripes, is the equipment-grounding conductor. If repair or replacement of the electric cord or plug is necessary, do not connect the equipment-grounding conductor to a live terminal.

Check with a qualified electrician or service personnel if the grounding instructions are not completely understood, or if in doubt as to whether the tool is properly grounded. Use only three wire extension cords that have three-prong grounding plugs and three-pole receptacles that accept the tool's plug.

Repair or replace a damaged or worn cord immediately.

115 Volt Operation

Referring to Figure 8:

As received from the factory, your Oscillating Edge Sander is ready to run at 115-volt operation. This Oscillating Edge Sander, when wired for 115 volt, is intended for use on a circuit that has an outlet and a plug that looks like the one illustrated in (A). A temporary adapter, which looks like the adapter shown in (B), may be used to connect this plug to a two-pole receptacle if a properly grounded outlet is not available.

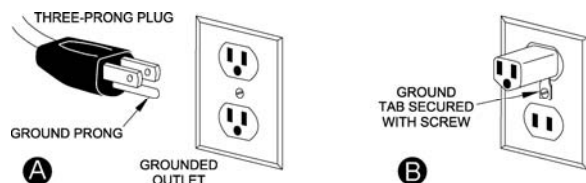

Figure 8

The temporary adapter should only be used until a properly grounded outlet can be installed by a qualified electrician. **This adapter is not applicable in Canada.** The green colored rigid ear, lug, or tab, extending from the adapter, must be connected to a permanent ground such as a properly grounded outlet box.

230 Volt Operation

Referring to Figure 9:

If 230V, single-phase operation is desired, the following instructions must be followed:

1. Disconnect the machine from the power source.
2. The JET Oscillating Edge Sander motor has four numbered leads that are factory connected for 115V operation, as shown in (A). For 230V operation reconnect the leads as shown in (B).
3. The 115V attachment plug (C) supplied with the Oscillating Edge Sander must be replaced with a UL/CSA listed plug suitable for 230V operation (D). Contact your local Authorized JET Service Center or qualified electrician for proper procedures to install the plug. The Oscillating Edge Sander must comply with all local and national codes after the 230-volt plug is installed.
4. The Oscillating Edge Sander with a 230-volt plug should only be connected to an outlet having the same configuration as shown in (D). No adapter is available nor should be used with the 230-volt plug.

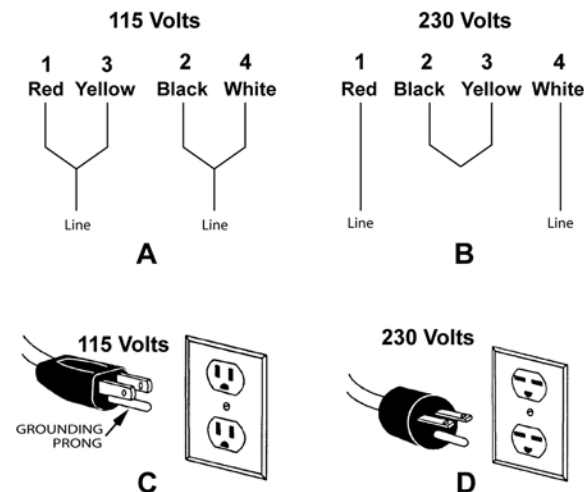

Figure 9

Extension Cords

Make sure your extension cord is in good condition. When using an extension cord, be sure to use one heavy enough to carry the current your machine will draw. An undersized cord will cause a drop in the line voltage resulting in power loss and overheating. Table 1 shows the correct size to use depending on the cord length and nameplate ampere rating. If in doubt, use the next heavier gauge. Remember, the smaller the gauge number, the heavier the cord.

Recommended Extension Cord Gauges

Amps	Extension Cord Length in Feet *					
	25	50	75	100	150	200
< 5	16	16	16	14	12	12
5 to 8	16	16	14	12	10	NR
8 to 12	14	14	12	10	NR	NR
12 to 15	12	12	10	10	NR	NR
15 to 20	10	10	10	NR	NR	NR
21 to 30	10	NR	NR	NR	NR	NR

*based on limiting the line voltage drop to 5V at 150% of the rated amperes.

NR: Not Recommended.

Table 1

Adjustments

Sanding Platen Angle Adjustment

Referring to Figure 10:

1. Disconnect the machine from the power source.
2. Pull the *lock handle* (B) forward (unlock) to release tension.

Move the *sanding platen* (A) to the desired position. Use a combination square between the table and sanding platen to get precise angles.

3. Hold the *platen* (A) while locking the handle.

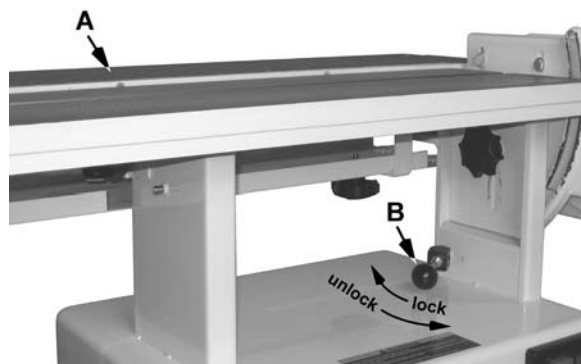

Figure 10

Platen Lock Tension Adjustment

1. Disconnect the machine from the power source.
2. Loosen (unlock) the *handle* (B, Fig. 10) and place the platen in the horizontal position as shown in (A, Fig. 10). Do not lock.
3. Tension eccentric block by tightening the nylon nut (B, Fig. 11) with a 14mm wrench. Turn the nut in by 1/4 turn increments and test locking handle for proper tension.

The *lock handle* is properly tensioned when it requires positive force to move the eccentric block (attached to the locking handle) from one side to the other. The platen and motor assembly must stay in a locked position without sliding once the handle has been moved to the locked position. Re-adjust as necessary.



Figure 11

Changing the Sanding Belt

Referring to Figure 12:

1. Disconnect the machine from the power source.
2. Lock the sanding platen in the vertical position (see the *Sanding Platen Angle Adjustment* section on page 12).
3. Release tension on the belt by loosening the *handle (C)*.
4. Loosen or remove the *lock knobs (B)* and remove the *belt guard (A)*.
5. Remove the old belt and install the new belt matching the direction of the arrows on the belt with the arrow label on the top of the platen.
6. Line up edge of belt with edge of rollers.
7. Place tension on the belt by moving the *tension arm handle (C)* to the *Tight* position.
8. Reinstall the *belt guard (A)* and tighten the *lock handles (B)*

Note: Belts stretch with wear. When a belt is replaced, you may have to adjust tracking.

Belt Tracking Adjustment

The *Belt Tracking Adjustment* is a fine adjustment procedure. The *Motor Mount Tracking Adjustment* (following section) is a course adjustment.

To adjust the belt tracking:

1. Disconnect the machine from the power source.
2. Push the belt by hand from left to right (the direction indicated top of the platen) and observe the belt's position on the rollers. The oscillating movement of the belt is by design. Observe the belt's range of movement from its highest to lowest position. The edges of the belt should not have a tendency to move above or below the edges of the rollers.

If adjustment is still necessary:

3. Insert the round shaft of the *belt tracking tool* (provided) into the *micro adjust lock nut (A)* and turn away from you to loosen.
4. Turn the *micro adjusting screw (B)* in 1/4 turn increments until the belt tracks evenly on the rollers when rotated by hand.
Tip: Moving the belt tracking tool *away* from you *raises* the belt on the drum and *towards* you *lowers* the belt on the drum.
5. Tighten the micro adjusting nut (A).

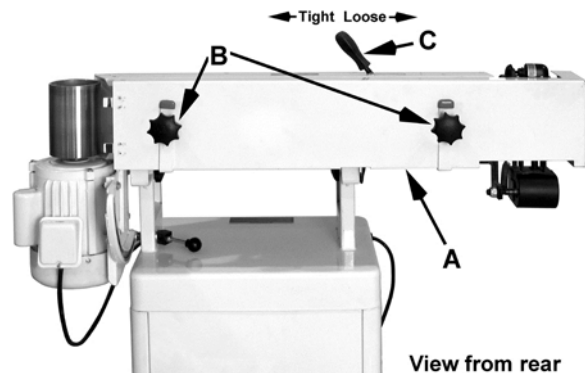

Figure 12

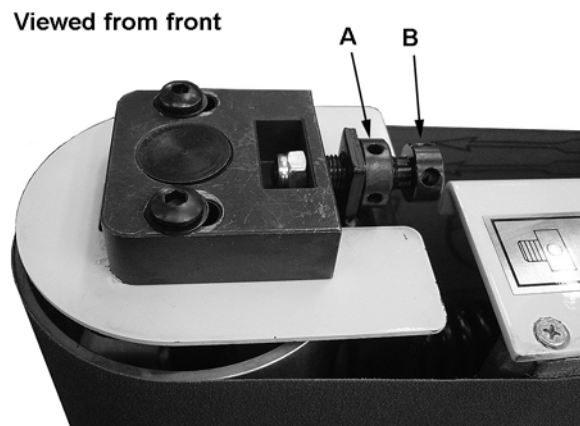

Figure 13

6. Connect the machine to power.
7. Turn on the power to the machine and observe the belt's up and down range of movement.
Adjustment is correct when the edges of the belt do not move above or below the edges of the rollers.
8. When adjustment is complete, tighten the *micro adjust lock nut (A)*.

If the tracking cannot be corrected go to the *Motor Mount Tracking Adjustment* section (next page).

Motor Mount Tracking Adjustment

Referring to Figure 14:

The OES-80CS comes with tracking adjustment bolts (A) on the motor plate. These are set at the factory and should not require any further adjustment. If, however, you are not able to track the belt with the *Belt Tracking Adjustment* described in the previous section, the motor mount bolts will have to be adjusted.

Note: The *Motor Mount Tracking Adjustment* is a *course* adjustment. Use the *Belt Tracking Adjustment* first for *fine* adjustment. If it cannot be adjusted, *then* use the procedure described below.

To adjust:

1. Disconnect the machine from the power source.
2. Slightly loosen the four *motor mount nuts* (B) just enough so the *tracking screws* (A) can be turned to make an adjustment.
3. Loosen the two *locking hex nuts* (C) that secure the *tracking screws* (A).
4. Turn one *screw* (A) a 1/4 turn and rotate the sanding belt by hand to observe which direction the adjustment is causing the belt to move. If it is traveling in the direction needed to correctly track the belt go to step 6.
5. If the belt starts to travel in the wrong direction, back off a quarter turn and *tighten the other screw* a quarter turn. This should start the belt moving in the proper direction.
6. Tighten both *locking nuts* (C) and *motor mount nuts* (B). Then return to the Belt Tracking Adjustment section (previous page) and again attempt to fine tune the tracking.

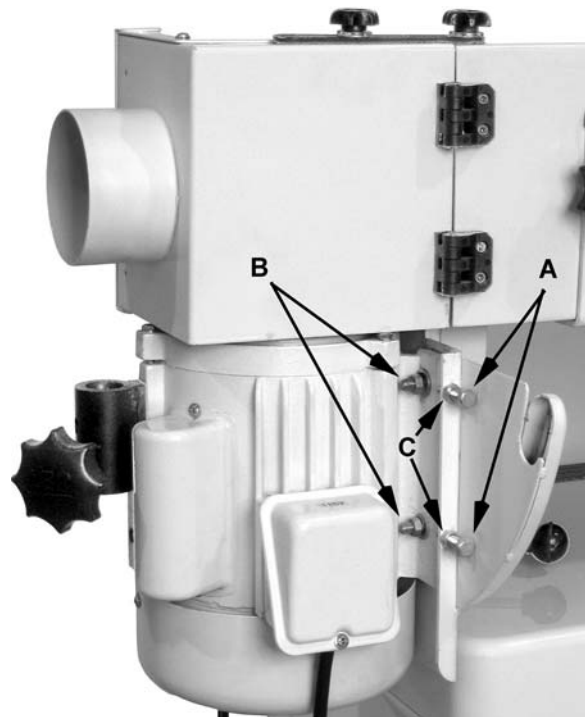

Figure 14

Table Adjustment

⚠WARNING Do not position table below sanding belt! Keep an overlap of at least 1/16" between table and sanding belt to avoid material and/or fingers getting caught! Failure to comply may cause serious injury!

1. Loosen two lock knobs (A, Fig. 15).
2. Raise or lower work table to desired level.
3. Tighten two lock knobs.

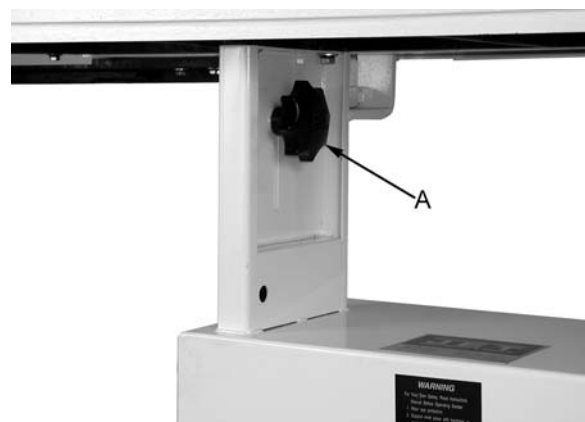

Figure 15

Basic Operations

⚠WARNING Removing the belt guard exposes more of the sanding belt! Replace the belt guards immediately after completing any sanding that requires its removal! Failure to comply may cause serious injury!

Horizontal Sanding

For *horizontal sanding*, the *platen* is locked in the horizontal position as shown (F) and the *removable fence* (D) is secured to the *table* (E) as follows.

Referring to Figure 16:

1. Place 5/16" *flat washers* (not shown) and *guide blocks* (B) on two 12mm *lock knobs* (A) – Note: the 12mm refers to the threaded shaft length.
2. Insert the *guide blocks* (B) into the *miter slot* (C) and position the *lock knobs* (G) on the *table* (E) as shown.
3. Place the *removable fence* (D) on the table and secure by tightening the *lock knobs* (G, Fig. 16 and Figure 17).

The *backstop* (H, Fig. 17) can also be used by swiveling the *drum guard & dust port* (J, Fig. 17) out of the way and placing the backstop pin in the positioning hole and securing in place with the *lock knob* (K, Fig. 17) and 5/16" *flat washer*. **Note:** This is better shown in Figure 18. The *drum guard & dust port* (J, Fig. 17) can then be returned to the position shown.

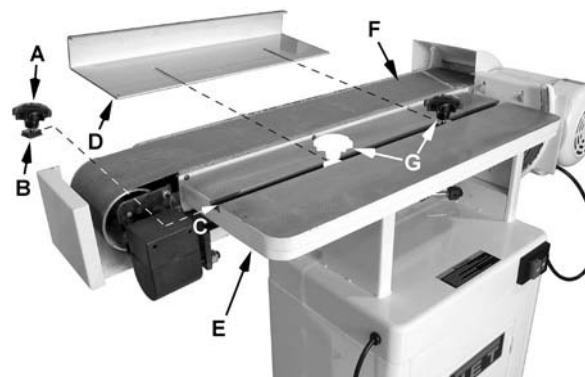

Figure 16

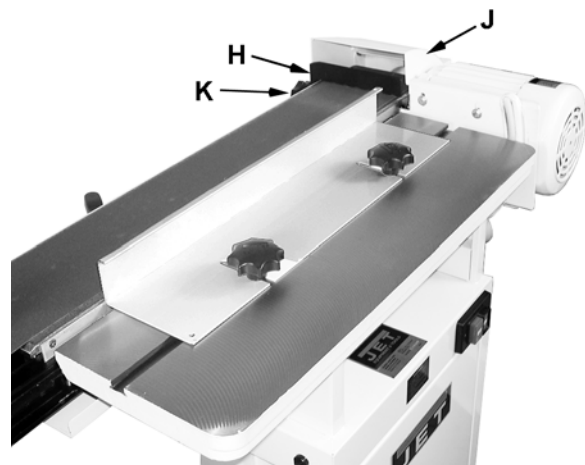

Figure 17

Vertical Sanding

Referring to Figure 18:

For *vertical sanding*, the *platen* (G) is locked in the vertical position as shown and the *backstop* (H) and/or the *miter gauge* (B) may be used.

Miter Gauge

1. Slide the *guide bar* (D) of the *miter gauge* (A) into the *miter slot* (C) on the table.
2. Set the miter angle; then secure the miter by tightening the *lock handle* (B).

Backstop

Place the backstop pin in the positioning hole and secure in place with the *lock knob* (E) and 5/16" *flat washer* (F).

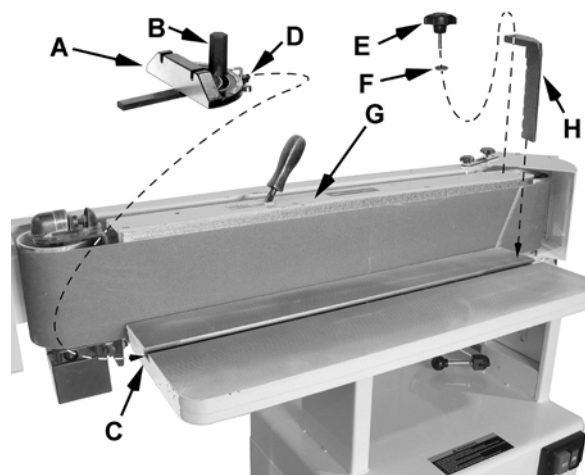

Figure 18

Contour Sanding

Referring to Figure 19:

Contour sanding is done from the extension table mounted on the motor where the sanding belt wraps around the *drive drum* (D). To set up the sander for contour sanding:

1. Loosen the two *lock knobs* (C) that secure the *drum guard & dust port* (E).
2. Swing the *end guard* (E) back, bringing the *drive drum* (D) into view.
3. Tighten the *lock knobs* (C).
4. Mount the *extension table* (A) to the sander by inserting the *post* (B) into the *bracket* (F).
5. Set the table to the desired height, then secure into position by tightening the *lock knob* (G).

Important: When the *extension table* (B) is not in use, the *drum guard & dust port* (E) should always be in the closed position so the *drive drum* (D) is not in view.

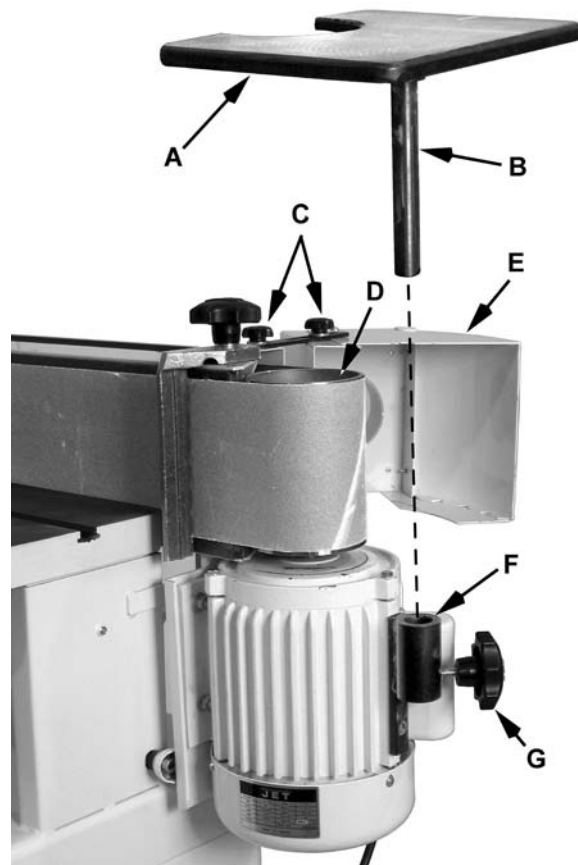

Figure 19

Troubleshooting Operating Problems

Trouble	Possible Cause	Solution
Sander will not start	<ol style="list-style-type: none"> 1. Sander unplugged from wall or motor 2. Fuse blown or circuit breaker tripped 3. Cord damaged 	<ol style="list-style-type: none"> 1. Check all plug connections 2. Replace fuse or reset circuit breaker 3. Replace cord
Sanding belt does not come up to speed	<ol style="list-style-type: none"> 1. Extension cord too light or too long 2. Motor not wired for proper voltage 3. Low current 	<ol style="list-style-type: none"> 1. Replace with adequate size and length cord (see <i>Recommended Extension Cord Gauges</i> on page 12) 2. Refer to motor junction cover for proper wiring 3. Contact a qualified electrician
Machine vibrates excessively	<ol style="list-style-type: none"> 1. Stand on uneven floor 2. Motor mounts are loose 3. Tension spring is worn or broken 	<ol style="list-style-type: none"> 1. Adjust stand so that it rests evenly on the floor 2. Tighten motor mount bolts 3. Replace spring
Abrasive belt keeps tearing	<ol style="list-style-type: none"> 1. Belt is running in the wrong direction 	<ol style="list-style-type: none"> 1. Arrow on the sanding belt and machine should be pointing in the same direction.
Sanded edge not square	<ol style="list-style-type: none"> 1. Table not square to sanding platen 	<ol style="list-style-type: none"> 1. Use a square to adjust table to sanding platen
Sanding marks on wood	<ol style="list-style-type: none"> 1. Wrong grit sanding belt 2. Feed pressure too great 3. Sanding against the grain 	<ol style="list-style-type: none"> 1. Use coarser grit for stock removal and fine grit for finish sanding. 2. Never force work into sanding platen 3. Sand with the grain

Parts

Ordering Replacement Parts

To order parts or reach our service department, call 1-800-274-6848 Monday through Friday (see our website for business hours, www.jettools.com). Having the Model Number and Serial Number of your machine available when you call will allow us to serve you quickly and accurately.

Table and Motor – Assembly

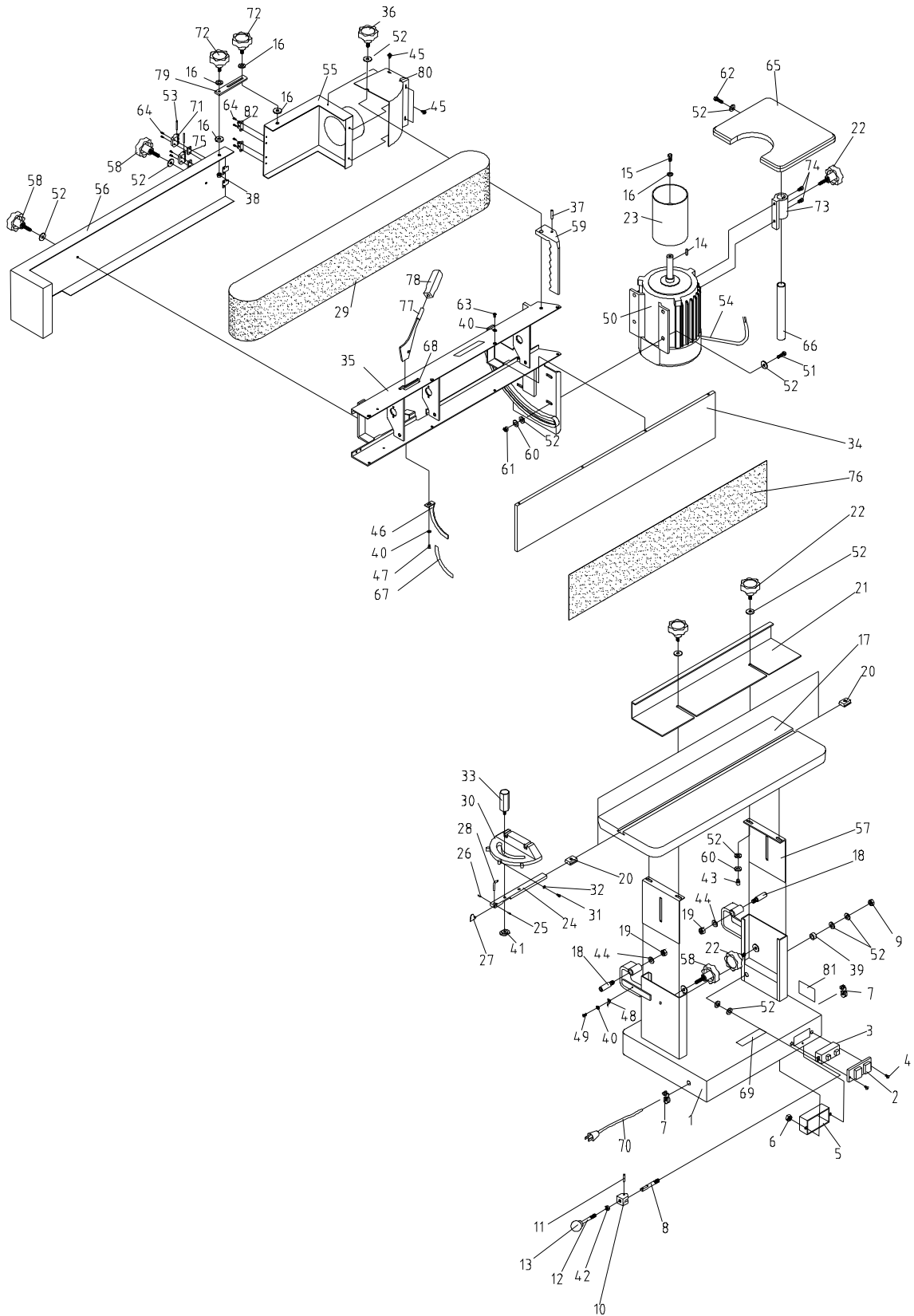

Table and Motor – Parts

Index No.	Part No.	Description	Size	Qty.
1	EHVS80CS-01	Base		1
2	EHVS80-02N	Push Button Switch		1
3	EHVS80-03N	Switch Panel		1
4	TS-081C082	Pan Head Screw	#10-24x1-1/2"	3
5	EHVS80-02B	Switch Box		1
6	TS-0560071	Hex Nut	#10-24	5
7	EHVS80-07	Strain Relief		2
8	EHVS80-08	Work Table Bar		1
9	EHVS80-09A	Nylon Insert Lock Nut	3/8"-24	1
10	EHVS80-10	Locking Block		1
11	EHVS80-11	Spring Pin	Ø4	1
12	EHVS80-12	Lock Handle		1
13	10102023A	Knob		1
	EHVS80-12A	Lock Handle Assembly (index #12,13)		1
14	S0430525	Key	5x5x25	1
15	TS-0050031	Hex Cap Screw	1/4"-20x3/4"	1
16	TS-0680021	Flat Washer	1/4"	5
17	EHVS80-17	Table		1
18	EHVS80-18	Screw	M10	2
19	TS-1540071	Hex Nut	M10	2
20	EHVS80-20	Guide Block		2
21	EHVS80-21	Fence		1
22	EHVS80-22A	JET Knob	M8x12mm	3
23	OES80CS-23	Drive Drum (<i>serial no. 05110394 and higher</i>)		1
24	EHVS80-24	Guide Bar		1
25	S0310306	Pin	Ø3	1
26	TS-0267021	Set Screw	1/4"-20x1/4"	1
27	EHVS80-27	Location Plate		1
28	EHVS80-28	Pointer		1
29		Sanding Belt (local purchase)	6"W x 89"L	1
30	10104046	Miter Gauge Body		1
	EHVS80-MG	Miter Gauge Assembly (index #20,24-28,30-33,41)		1
31	TS-081B042	Pan Head Screw	#8-32x5/8"	3
32	TS-0560061	Hex Nut	#8-32	3
33	EHVS80-33	Knob		1
34	20101048	Platen		1
35	OES80CS-135	Side Plate		1
	TS-0051061	Hex Cap Screw (motor plate – not shown)	5/16"-18x1-1/4"	2
	TS-0561021	Hex Nut (motor plate – not shown)	5/16"-18	2
36	EHVS80-36A	JET Knob	M8x35mm	1
37	EHVS80-37A	Pin	Ø6x40mm	1
38	TS-0561011	Hex Nut	1/4"-20	2
39	EHVS80-39A	Spacer		1
40	TS-0733031	External Tooth Lock Washer	#10	11
41	EHVS80-28A	Location Block		1
42	TS-0561031	Hex Nut	3/8"-16	1
43	TS-0051021	Hex Cap Screw	5/16"-18x5/8"	4
44	TS-0720091	Lock Washer	3/8"	2
45	EHVS80-49	Washer Head Screw	#10-24 x 3/8"	3
46	EHVS80-57	Tilt Scale		1
47	TS-081C052	Pan Head Screw	#10-24x3/4"	1
48	EHVS80-59	Pointer		1
49	TS-081C022	Pan Head Screw	#10-24x3/8"	2
50	OES80CS-150	Motor	1-1/2HP, 1PH	1
51	TS-0051061	Hex Cap Screw	5/16"-18x1-1/4"	5

Table and Motor – Parts

Index No.	Part No.	Description	Size	Qty.
52	TS-0680031	Flat Washer	5/16"	10
53	OES80CS-153	Pin		2
54	EHVS80-67	Motor Cord		1
55	OES80CS-155	Dust Port		1
56	OES80CS-156	Sanding Belt Cover		1
57	EHVS80-70A	Up-Down Table Mount Plate		2
58	EHVS80-71A	JET Knob	M8X20mm	4
59	EHVS80-72	Back Stop Bracket		1
60	TS-0720081	Lock Washer	5/16"	14
61	TS-0561021	Hex Nut	5/16"-18	6
62	TS-0051061	Hex Cap Screw	5/16"-18x1-1/4"	2
63	TS-2285121	Flat Head Screw	M5x12	8
64	TS-2284201	Flat Head Screw	M4x20	8
65	EHVS80-94	Extension Table		1
66	EHVS80-96	Supporting Rod		1
67	EHVS80-57A	Tilt Angle Scale Label		1
68	EHVS80-108	Direction Label		1
69	EHVS80-107	Warning Label		1
70	EHVS80-68	Power Cord		1
71	OES80CS-171	Hinge		2
72	OES80CS-172	Knob	M6	2
73	OES80CS-173	Supporting Seat		1
74	TS-0206041	Socket Head Cap Screw	#10-24x3/4"	2
75	OES80CS-175	Spacer		2
76	EHVS80-34G	Graphite Pad		1
77	EHVS80-51	Belt Tension Arm		1
78	EHVS80-54	Tension Arm Handle		1
79	OES80CS-179	Connection Plate		1
80	EHVS80-111	Drum Guard		1
81	OES80CS-181	ID Label		1
82	OES80CS-182	Hinge Bracket		2

Idle Drum – Assembly

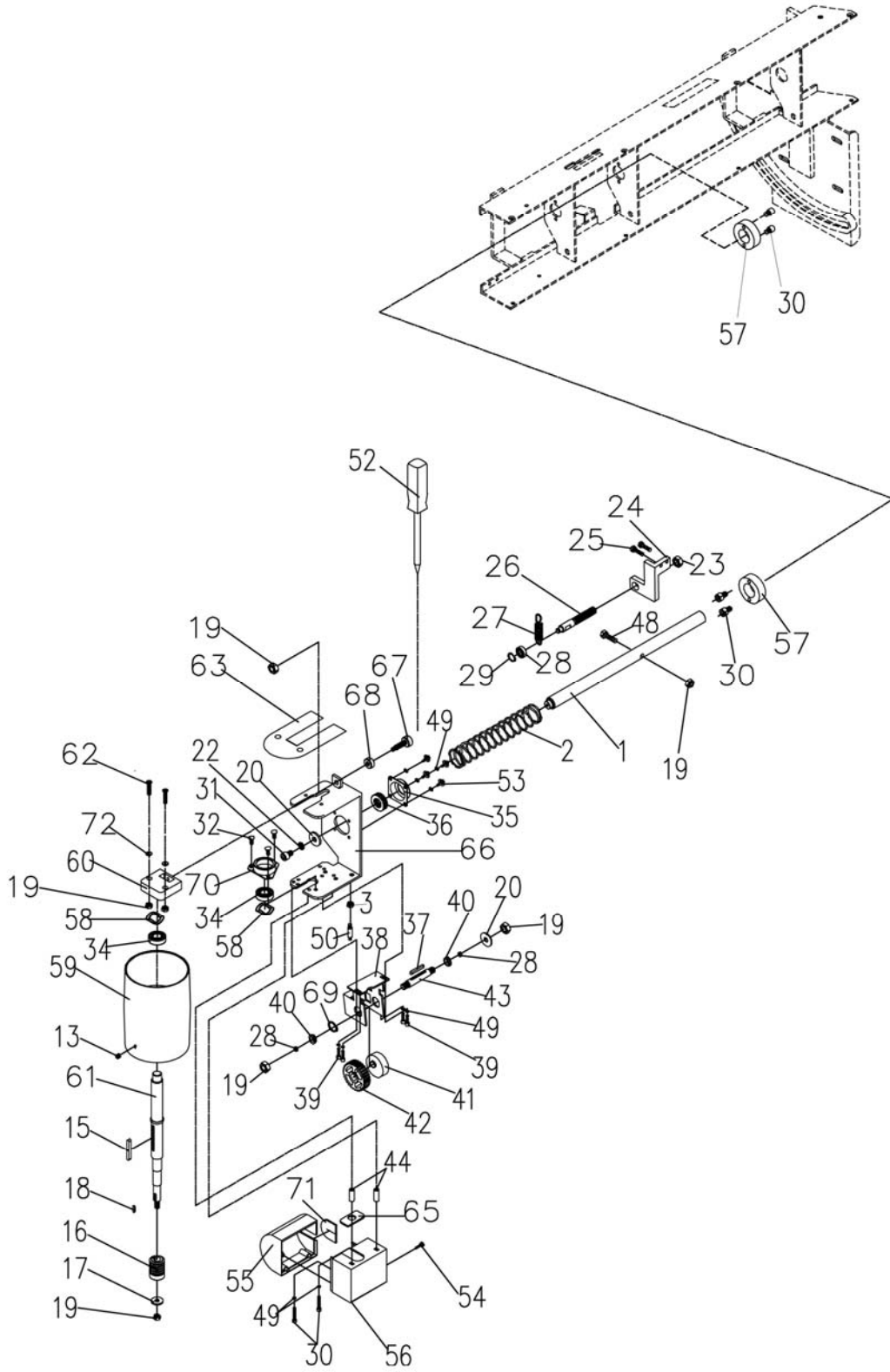

Idle Drum – Parts

Index No.	Part No.	Description	Size	Qty.
.....	OES80CS-IDRA.....	Idle Drum Complete Assembly (index # 1-72)		1
1.....	OES80CS-201	Tension Bar.....		1
2.....	OES80CS-203.....	Spring.....		1
3.....	TS-0561021	Hex Nut.....	5/16"	1
13.....	TS-1523011	Socket Set Screw	M6x6	2
15.....	S0400545	Key.....	5x5x45mm.....	1
16.....	OES80CS-216	Worm		1
17.....	OES80CS-217	Spacer.....		1
18.....	S0400425	Key.....	4x4x25	1
19.....	TS-0640081	Nylon Insert Lock Nut	5/16"	6
20.....	TS-0680031	Flat Washer.....	5/16"	4
22.....	TS-0720081	Lock Washer	5/16"	6
23.....	TS-2342141	Nylon Insert Lock Nut	M14.....	2
24.....	OES80CS-224	Bracket.....		1
25.....	TS-0050031	Hex Cap Screw	1/4"-20x3/4"	2
26.....	OES80CS-226N.....	Lead Screw		1
27.....	OES80CS-227	Spring.....		1
28.....	OES80CS-228	Ball Bearing.....	698	3
29.....	OES80CS-229	Retaining Ring.....	STW-8.....	1
30.....	TS-1502051	Socket Head Cap Screw.....	M5x20	2
31.....	TS-0208061	Socket Head Cap Screw.....	5/16"x1"	1
32.....	TS-2284121	Flat Head Screw	M4x12	3
34.....	BB-6202VV	Ball Bearing.....	6202LLU	2
35.....	OES80CS-235	Bearing Housing.....		1
36.....	BB6003ZZ	Ball Bearing.....	6003ZZ.....	1
37.....	S0400430	Key.....	4x4x30	1
38.....	OES80CS-238	Gear Housing		1
39.....	TS-1502021	Socket Head Cap Screw.....	M5x10	5
40.....	OES80CS-240	Bushing.....		2
41.....	OES80CS-241	Cam		1
42.....	OES80CS-242	Worm Gear.....		1
43.....	OES80CS-243	Worm Gear Shaft.....		1
44.....	OES80CS-244	Column.....		2
48.....	TS-0051081	Hex Cap Screw	5/16"-18x1-3/4"	1
49.....	TS-1551031	Lock Washer	M5.....	6
50.....	OES80CS-250	Rod		1
52.....	EHVS80-81	Belt Tracking Tool.....		1
53.....	TS-0810012	Round Head Slotted Machine Screw.....	#10-24x1/4"	4
54.....	OES80CS-254	Self Tapping Screw	M3x6	1
55.....	OES80CS-255	Dust Hood (Left).....		1
56.....	OES80CS-256	Dust Hood (Right).....		1
57.....	OES80CS-257	Ring		2
58.....	OES80CS-258	Wave Washer.....		2
59.....	OES80CS-259	Idle Drum		1
60.....	OES80CS-260	Track Adjusting Block		1
61.....	OES80CS-261	Drive Shaft		1
62.....	OES80CS-262	Button Head Socket Screw	5/16"X1-3/4	2
63.....	OES80CS-263	Guard.....		1
65.....	OES80CS-265	Foam Sheet for Drive Shaft		1
66.....	OES80CS-266	Idle Drum Bracket.....		1
67.....	OES80CS-267	Track Adjusting Screw.....		1
68.....	OES80CS-268	Track Adjusting Nut		1
69.....	OES80CS-269	Retaining Ring.....	S10	1
70.....	OES80CS-270	Bearing Housing.....		1
71.....	OES80CS-271	Foam Sheet for Lead Screw		1
72.....	OES80CS-272	Cone Disc Spring.....		2

Stand Assembly

Index No.	Part No.	Description	Size	Qty.
1	TS-0680031	Flat Washer	5/16"	22
2	TS-0720081	Lock Washer	5/16"	10
3	TS-0561021	Hex Nut	5/16"-18	8
4	EHVS80CS-S04	Side Panel		2
5	EHVS80CS-S05	Pad		4
6	EHVS80CS-S06	Screw		4
7	EHVS80CS-S07	Rear Panel		1
8	TS-0561021	Hex Nut	5/16"-18	4
9	TS-0051061	Hex Cap Screw	5/16"-18x1-1/4"	2
10	TS-1533032	Pan Head Screw	M5x10	2
11	EHVS80CS-S11	Door		1
12	EHVS80CS-S12	Shelf		1
13	EHVS80CS-S13	Latch Assembly		1
14	TS-1551031	Lock Washer	M5	2
15	EHVS80CS-S15	Front Panel (W/Door)		1
16	EHVS80CS-S16	Screw		2
17	EHVS80CS-S17	JET Label		1
18	TS-1550031	Flat Washer	M5	2
19	TS-0081031	Hex Cap Screw	5/16"-18x3/4"	8
	STRIPE-1-3/4	JET Stripe (not shown)	1-3/4"w	per ft.

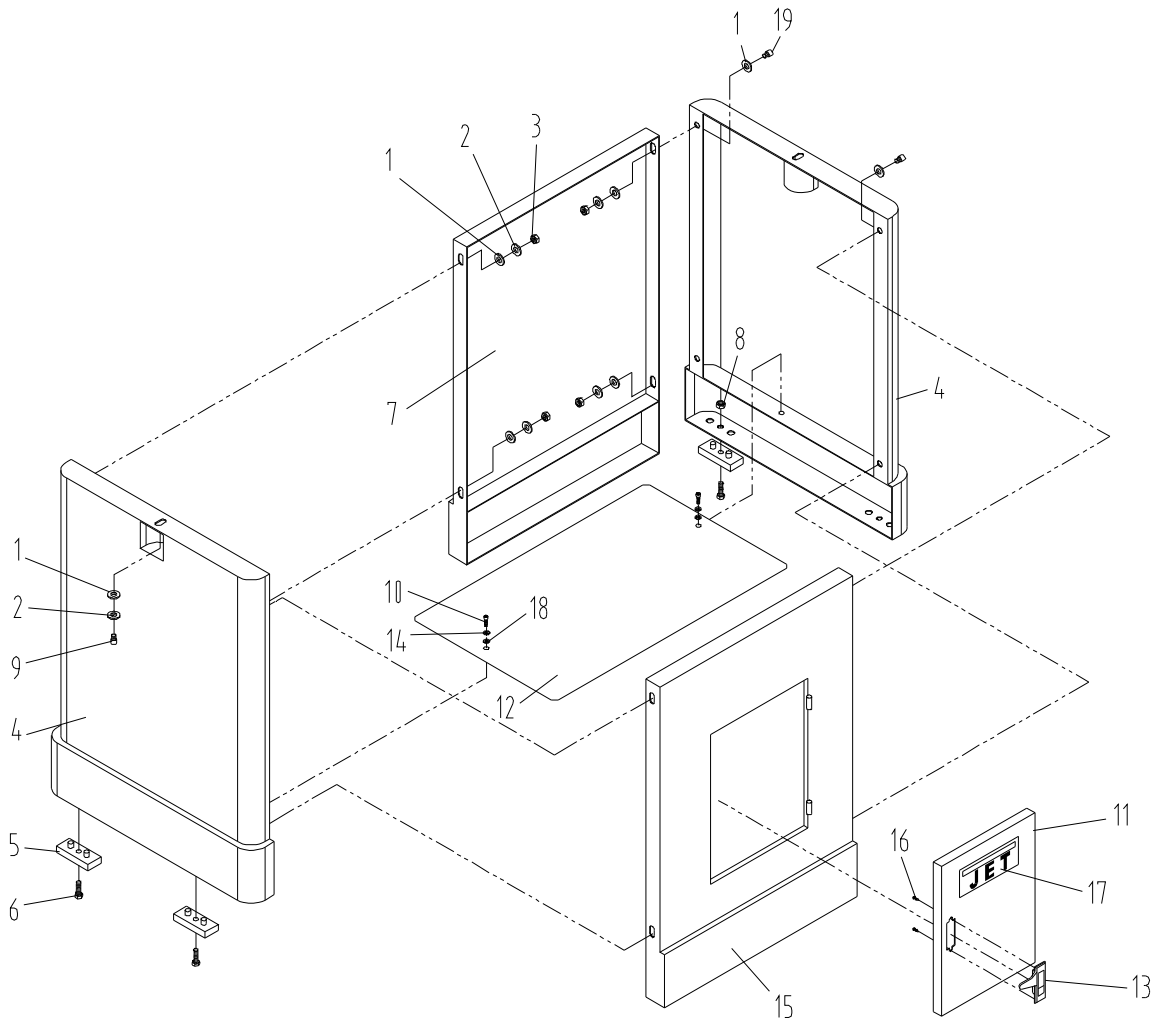

Wiring Diagram

EHVS-80CS ELECTRICAL SCHEMATIC-115V

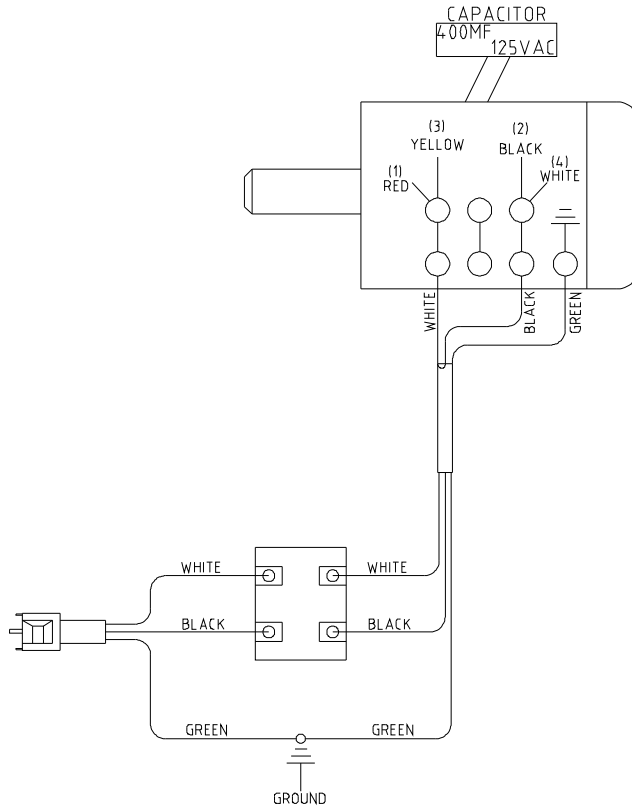

EHVS-80CS ELECTRICAL SCHEMATIC-230V

